



ATTACHMENTS

DOUBLE FORKS SYSTEM



**MULTIPURPOSE
MACHINE THAT
DELIVERS
IN EVERY SITUATION**



DOUBLE FORKS SYSTEM

Meclift Variable Reach Trucks equipped with Double Forks System considerably improve the efficiency in cargo handling.

As an easily mountable specialized attachment, it provides a multitude of benefits when loading and unloading containers and trailers. You can handle, for example, a total of four euro pallets or a similar load on one lift. Using the double forks saves time in container and trailer loading. For example, a 20 ft container can be fully loaded with only two lifts.

The weight of the load is not an issue, as the double forks can handle the same maximum capacity as the machine. The first side shift features of the machine can still be fully utilized, so positioning cargo inside a container is safe and secure. Also, switching between standard and double forks is quick, because the double forks use the same fixing points as the standard forks.

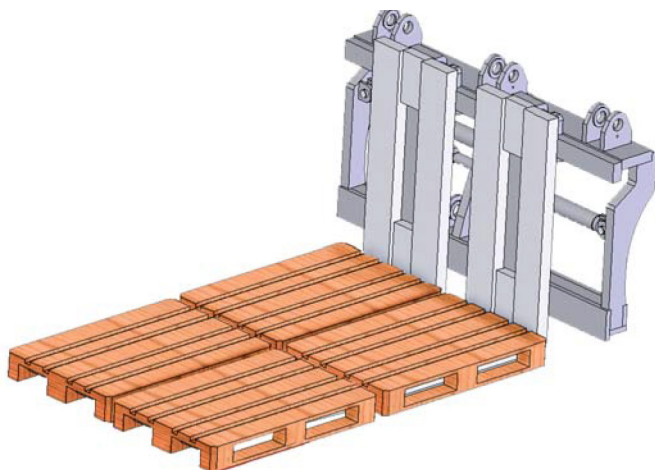

"Before we used eight forklifts for these tasks. Now we need only one ML1612R."

Meclift Customer

Double Forks System - technical specifications

Height	1 350 mm
Length, fork	2 400 mm
Length, assembly	2 570 mm
Width, fork pair	570 mm
Width, single fork	200 mm
Thickness	70 mm
Lifting capacity, single fork	8 780 kg at a load center of 600 mm
Lifting capacity, total Double Forks System	16 000 kg at a load center of 1 200 mm (which is the lifting capacity of the ML1612R)
Weight, fork pair	780 kg
Weight, total Double Forks System	1 560 kg

The Double Fork System can be used with all Meclift Variable Reach Truck models. The above technical specifications are valid for ML1612R. Manufactured in Finland.

Mecalift Oy
 Ristinarkuntie 20
 FI-33560 Tampere, Finland
 Tel. +358 400 403 593
 sales@meclift.fi

WWW.MECLIFT.FI

