



ATTACHMENTS **COIL RAM**



**MULTIPURPOSE
MACHINE THAT
DELIVERS
IN EVERY SITUATION**



COIL RAM

A Meclift Variable Reach Truck equipped with a Coil Ram is a superior combination for steel coil handling. It saves time and money and enhances safety at work.

The Meclift Variable Reach Truck with a Coil Ram attachment is a superior combination when handling steel coils. Utilizing a Coil Ram, any Meclift Variable Reach Truck can handle coils within its lifting capacity. ML1612R, for example, can handle coils up to 16 000 kg. Thanks to its compact size, loading a container from the back end by driving the load inside the container is effortless. By exploitation of the 2 500 mm reach, it is also possible to load the container from the outside. A side shift feature facilitates the positioning of cargo. For handling heavier loads, Meclift also offers ML3012RC with Coil Ram attachment. The unique structure and functionality of the boom and the lift carriage enable this type of machine to reach loads inside a container. To supply a solution that best meets your work environment, we customize the Coil Ram dimensions according to your request.

"Both safety and speed have improved since our customers started to operate with a ML1612R equipped with a Coil Ram. Some of the operations take less than 10% of the time needed in the past. Also significantly less people are needed when operating with the innovative Meclift equipment."

Mr. Fabio Giusa & Mr. Renato Scholz
Meclift representatives Brazil
F&F Comércio e Representações Ltda

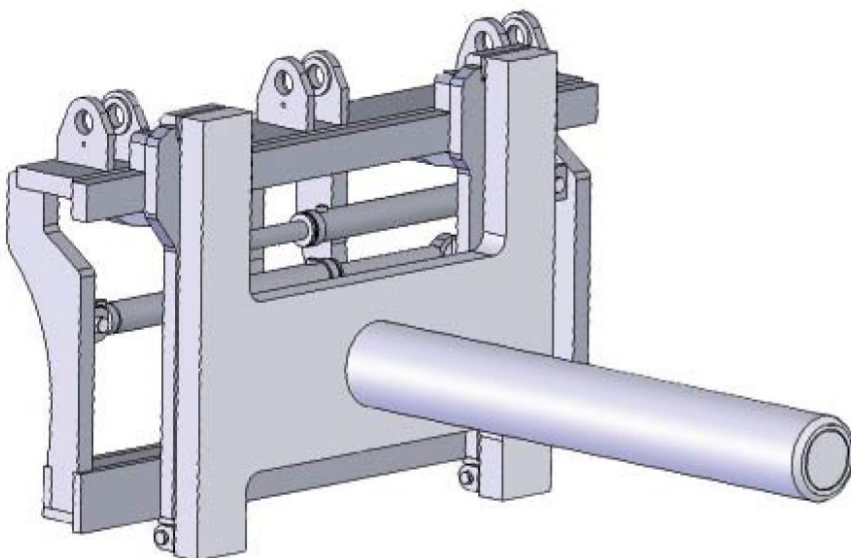

Mecalift Oy
Ristinarkuntie 20
FI-33560 Tampere, Finland
Tel. +358 400 403 593
sales@meclift.fi

WWW.MECLIFT.FI

