

MECLIFT

ATTACHMENTS COIL CLAMPS



**MULTIPURPOSE
MACHINE THAT
DELIVERS
IN EVERY SITUATION**



COIL CLAMPS

By combining the strength of a Coil Clamps attachment and the excellent reaching ability of Meclift Variable Reach Trucks, you get an efficient and safe solution for diverse tasks in cargo handling.

Utilizing Coil Clamps, any Meclift Variable Reach Truck can handle coils within its lifting capacity. ML1612R, for example, can handle coils up to 16 000 kg. Meclift Variable Reach Trucks equipped with the Coil Clamps can also be used to load and unload containers or trailers. Switching from one work phase to another is effortless and quick due to the simple change of tools. Because working conditions vary from location to location, the Coil Clamps can be tailored and adjusted according to each customer's specific needs. A Coil Clamps delivery always includes a particular stand for storing purposes.

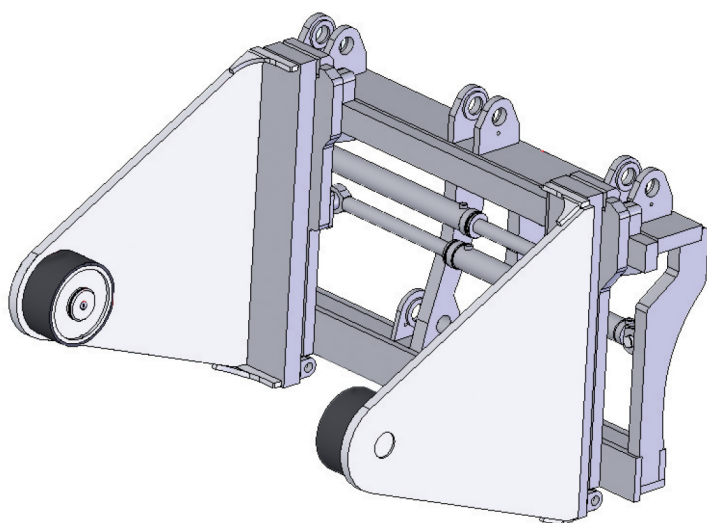

Coil Clamps - technical specifications

Distance between side plates	618 to 2 198 mm
Distance between cylinder surfaces	292 to 1 872 mm
Distance from back plate to cylinder surface	842 mm
Distance from back plate to cylinder center	1 005 mm
Cylinder diameter	325 mm
Cylinder collar width	145 mm
Weight, single clamp	510 kg
Weight, clamp pair	1 020 kg
Weight, stand	95 kg
Total weight	1 115 kg including the stand

The Coil Clamps can be used with all Meclift Variable Reach Truck models. The above technical specifications are valid for ML1612R. Manufactured in Finland.

Mecalift Oy
 Ristinarkuntie 20
 FI-33560 Tampere, Finland
 Tel. +358 400 403 593
 sales@meclift.fi

WWW.MECLIFT.FI



"Working with Meclift machinery, has made our operations safer, cheaper and faster."

Meclift Customer